

# Turbo SERIES

Electric and Air Pumps

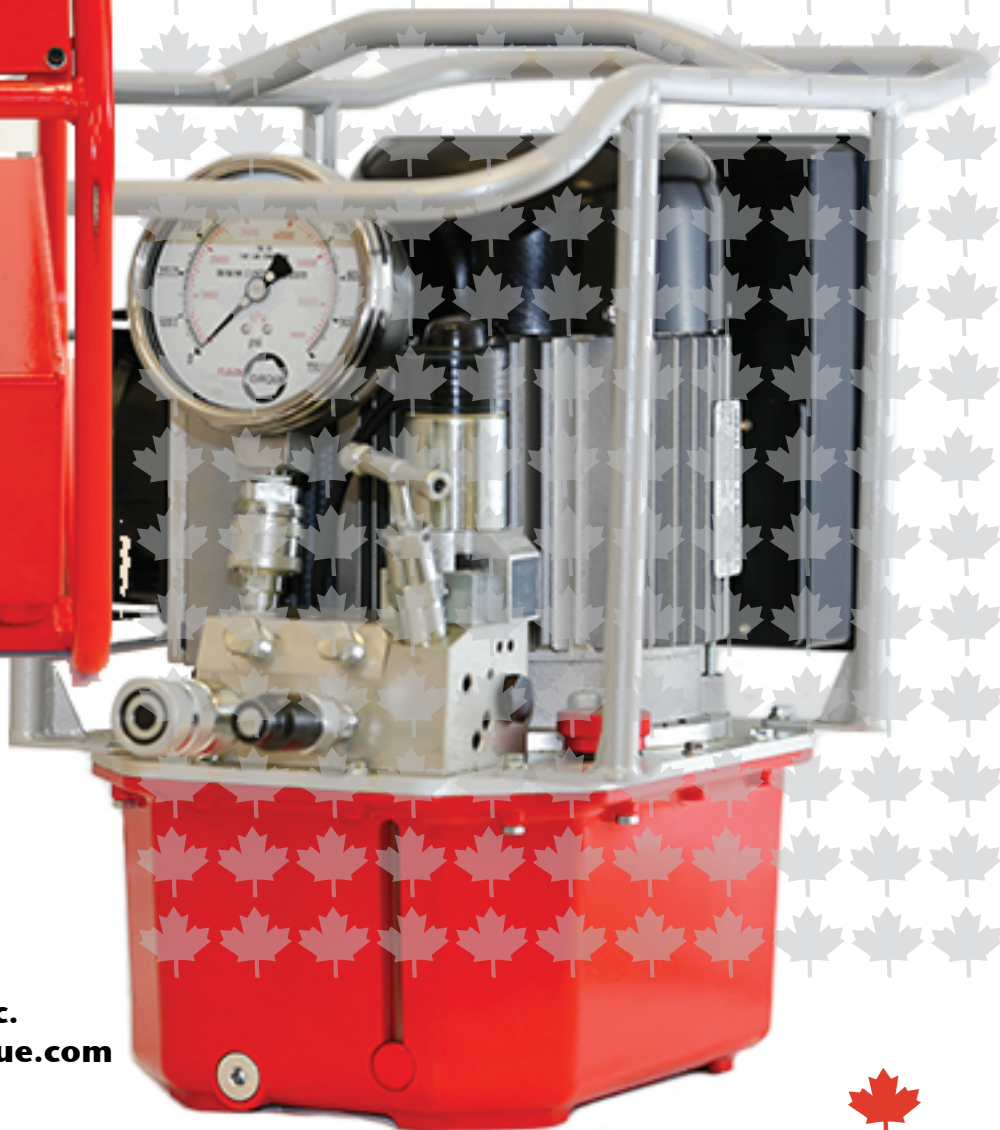

CanTorque Inc.  
[www.cantorque.com](http://www.cantorque.com)

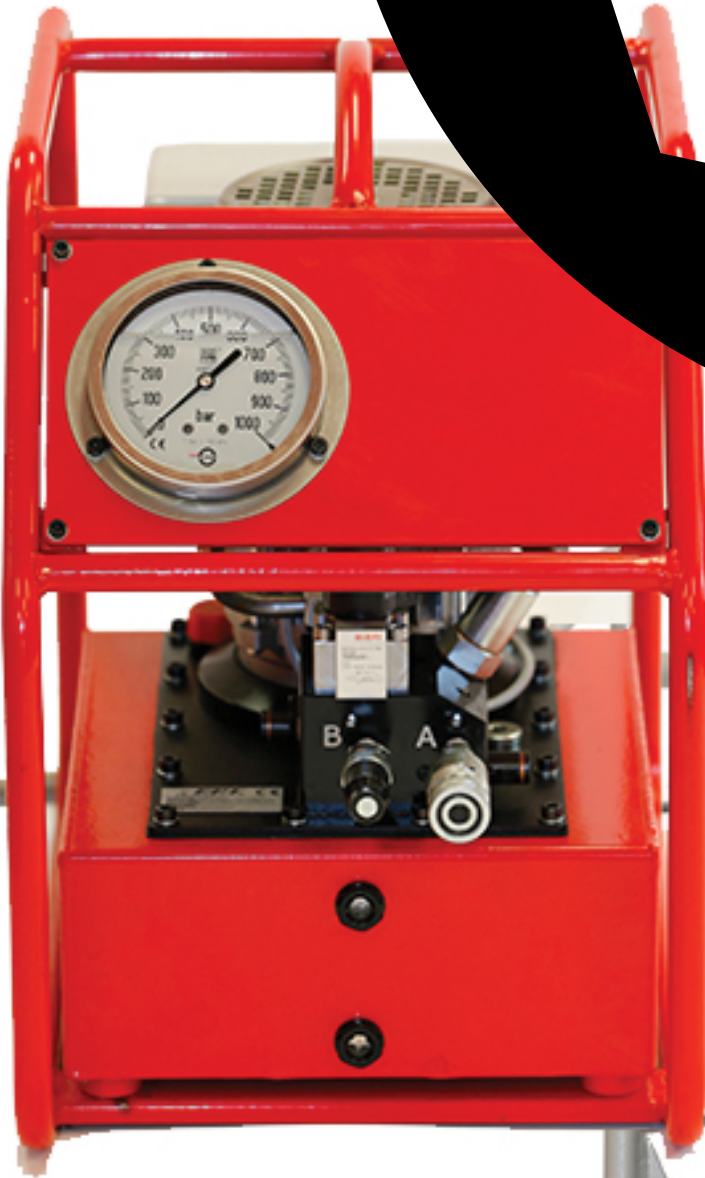

# Turbo Series

## Electric Pump

### TE-1000

- Single phase motor
- Two stage
- Starts under full load
- 115V and 230V available
- Site glass standard to monitor oil level
- Multi-port manifold (max 4 ports) optional
- Precise PSI/BAR pressure gauge
- Quick connect, no drip couplers
- Supplied with dual, non-conductive high pressure 4.5m hose set
- Hose sets available in custom length
- Completely enclosed motor housing and electronics
- Rugged remote pendant to control motor and valve

### Specifications

- Reservoir: 7.6 litre
- Voltage: 115V
- Frequency: 60Hz
- Power: 1.5 KW
- Flow rate: 7.5-0.9 lpm
- Oil tank capacity: 10 L
- Output pressure: 70-700bar
- Weight: 36kg
- Dimension: 320\*485\*480mm
- Motor revolution: 2850 rpm
- Valve Control: Solenoid

Specifications may change without notice.

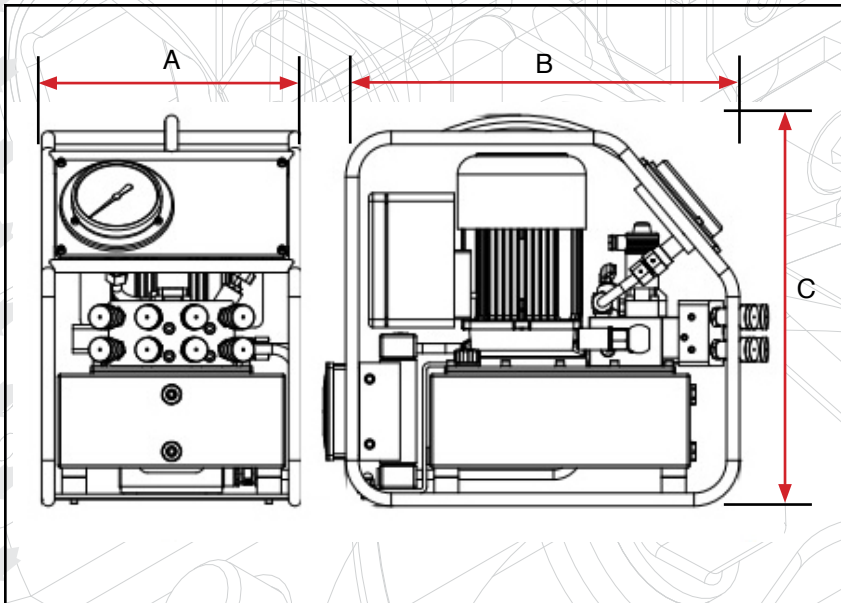

TE-1000 Dimensions



TE-1000 (optional Quadra Port)



# Turbo Series

Electric Pump

## TE-1000-MC

- Three stage delivery
- Starts under full load
- 115V and 220V available
- Site glass standard to monitor oil level
- Standard dual port, optional 4 port available
- Precise PSI/BAR pressure gauge
- Quick connect, no drip couplers
- Supplied with dual, non-conductive high pressure 4.5 m hose set
- Hose sets available in custom length
- Completely enclosed motor housing and electronics
- Acceptable working temperature -28C to 48C

## Specifications

- Voltage: 115V
- Frequency: 60Hz
- Power: 1.1KW
- Flow rate: 8.6-1.8-0.82 lpm
- Oil tank capacity: 8L
- Output pressure: 70-700bar
- Weight: 25kg
- Dimension: 305\*445\*426mm
- Motor revolution: 3445 rpm
- Amperage: 12.6 A
- Valve Control: Solenoid

Specifications may change without notice.

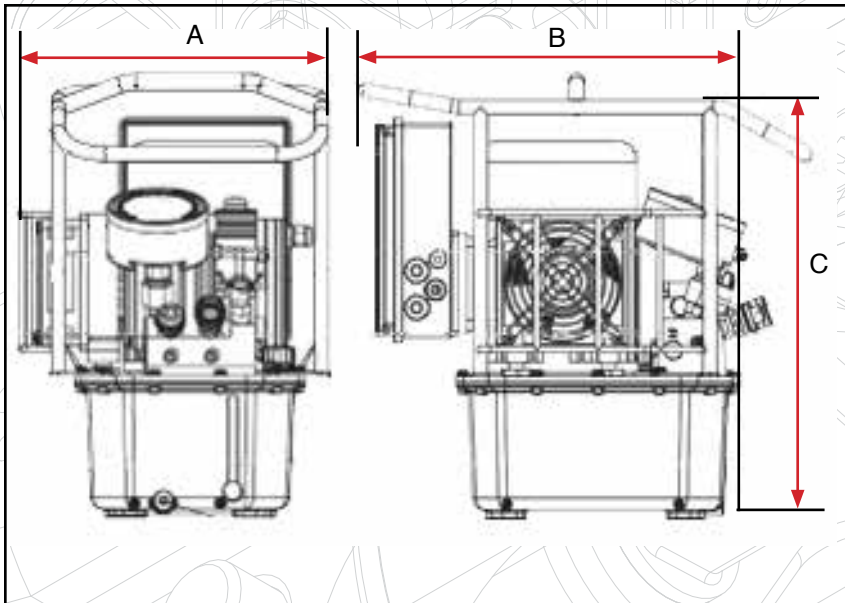

TE-1000-MC Dimensions



TE-1000 MC



info@cantorque.com



# Turbo Series

## Air Pump

### TA-1000

- Single phase motor
- Two stage
- Starts under full load
- Site glass standard to monitor oil level
- Multi-port manifold (max 4 ports) optional
- Precise PSI/BAR pressure gauge
- Quick connect, no drip couplers
- Supplied with dual, non-conductive high pressure 4.5m hose set
- Hose sets available in custom length
- Completely enclosed motor housing and electronics
- Rugged remote pendant to control motor and valve

### Specifications

- Power: 3 KW
- Flow rate: 7.5-0.9 lpm
- Oil tank capacity: 10 L
- Output pressure: 70-700bar
- Weight: 34kg
- Dimension: 320\*485\*480mm
- Motor revolution: 3000 rpm
- Valve Control: Solenoid

Specifications may change without notice.

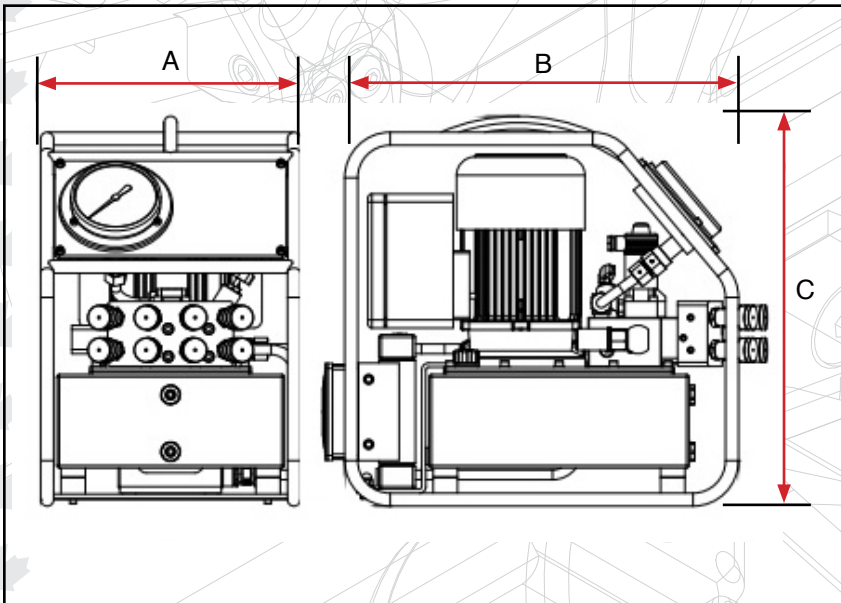

TA-1000 Dimensions



TA-1000 (optional Quadra Port)

CT® Authorized Distributor

 [info@cantorque.com](mailto:info@cantorque.com)

14635 119 Avenue  
Edmonton, AB T5L 2N9  
Twitter: @cantorque  
facebook.com/CanTorque

Main: +1 780 436 2000  
Fax: +1 780 732 0905  
Toll Free: +1 877 436 4364  
[www.cantorque.com](http://www.cantorque.com)